

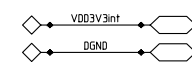

DWG. NO.	SH	REV	1
REVISIONS			
REV	DESCRIPTION	DATE	APPROVED

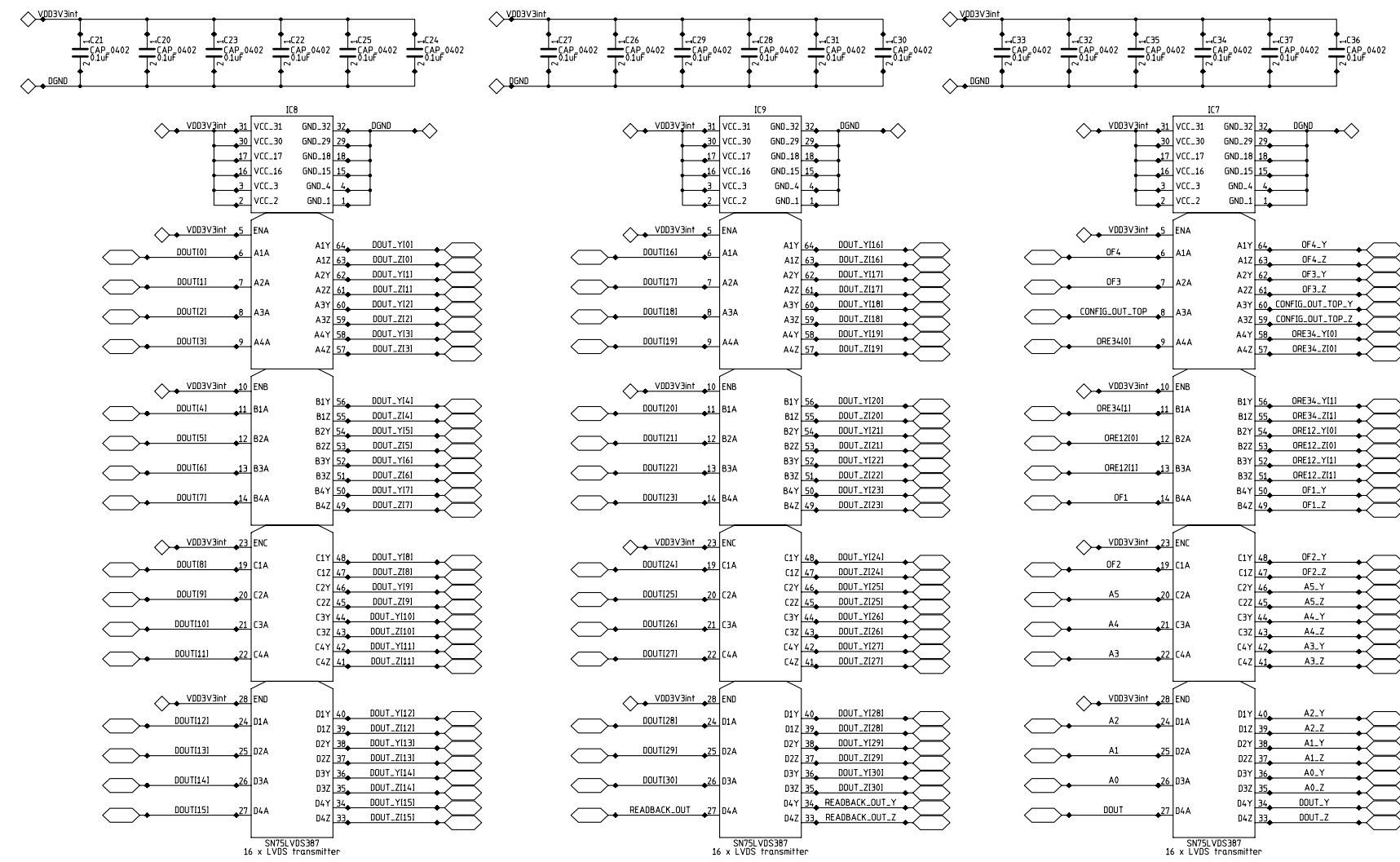

CONTRACT NO.			
APPROVALS	DATE		
DRAWN		LVDS transmitters	
CHECKED		SIZE / FSCM NO.	DWG. NO.
ISSUED		D	
		SCALE	SHEET



DWG. NO.	SH	REV	1
REVISIONS			
REV	DESCRIPTION	DATE	APPROVED

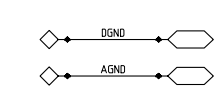
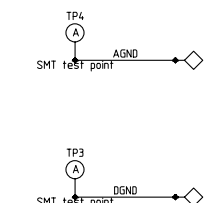
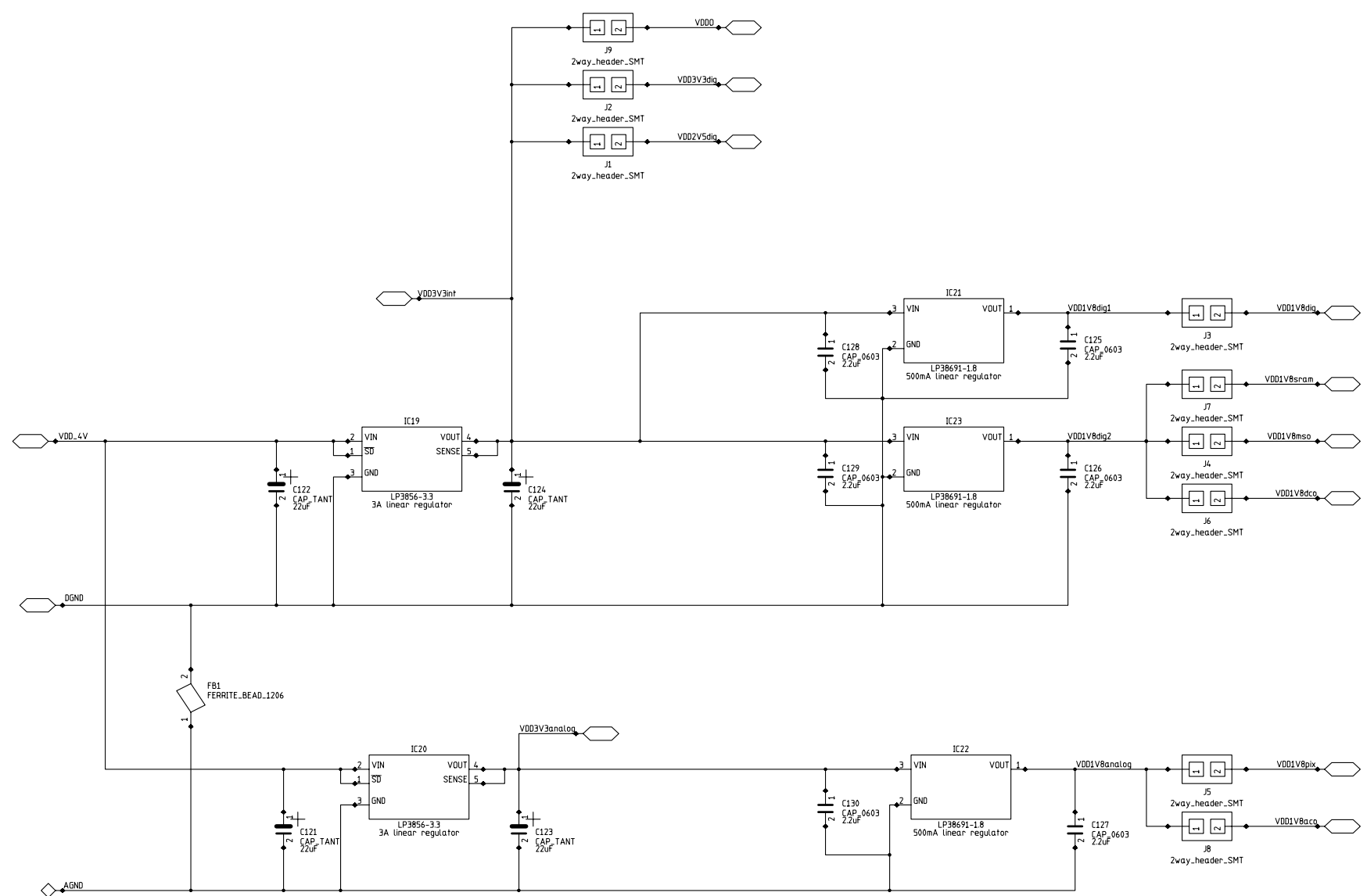

CONTRACT NO.			
APPROVALS	DATE	Power Supply	
DRAWN			
CHECKED			
ISSUED			
SCALE		SIZE / FSCM NO. D	DWG. NO.
			REV
			SHEET

REVISIONS			
REV	DESCRIPTION	DATE	APPROVED

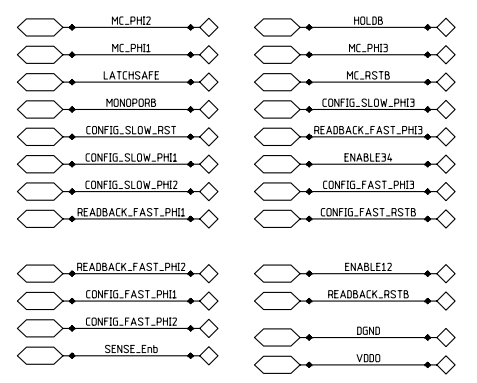
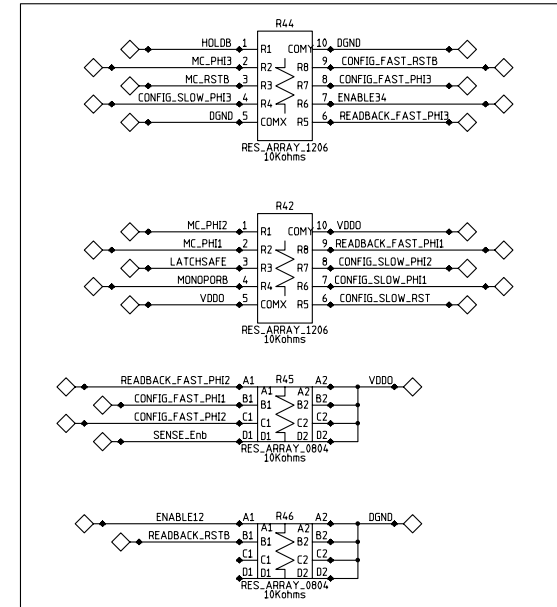
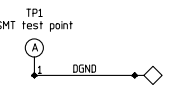
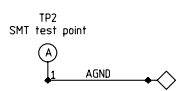
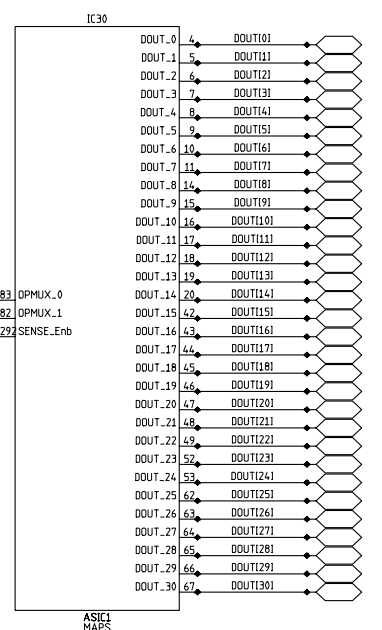
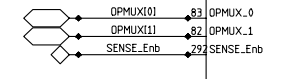
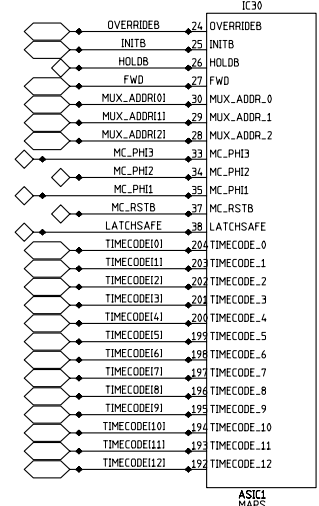
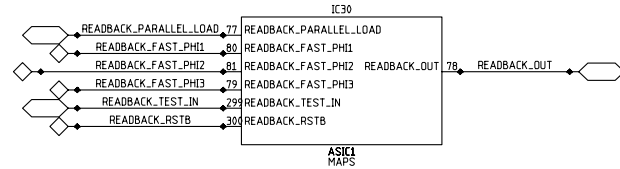
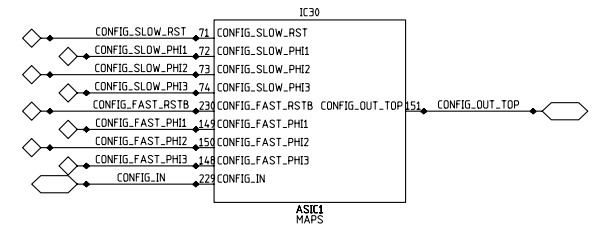
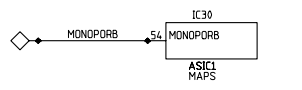
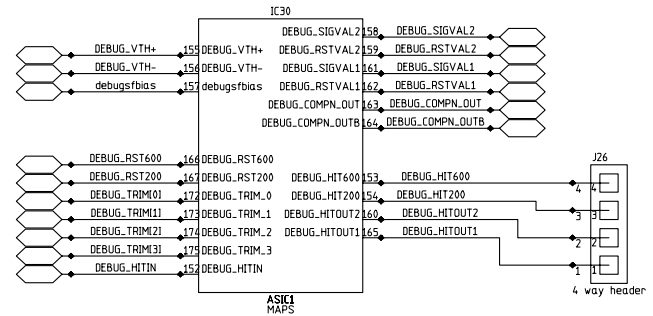
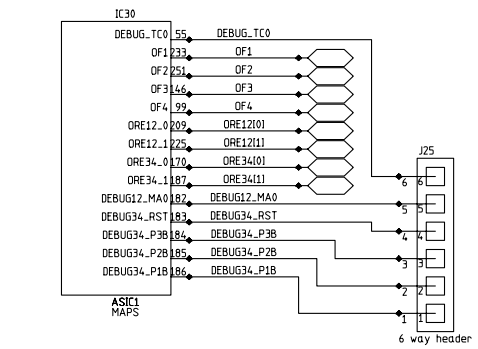
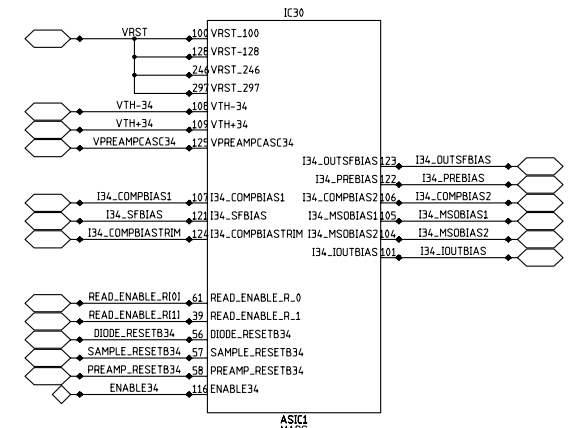
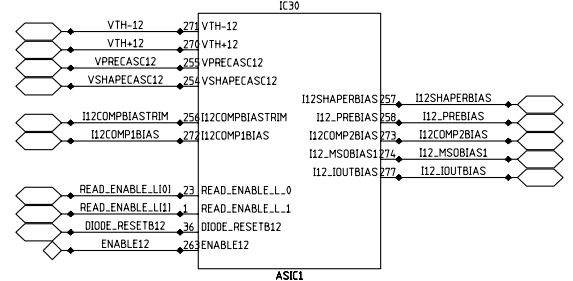
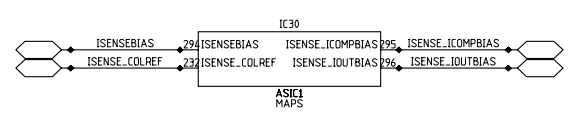

CONTRACT NO.		APPROVALS		DATE	
DRAWN		CHECKED		ISSUED	
SIZE		FSCM NO.		DWG. NO.	
SCALE		SHEET		REV	

Sensor: Signals

REVISIONS			
REV	DESCRIPTION	DATE	APPROVED

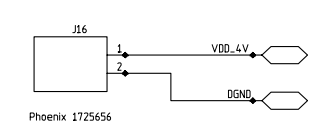
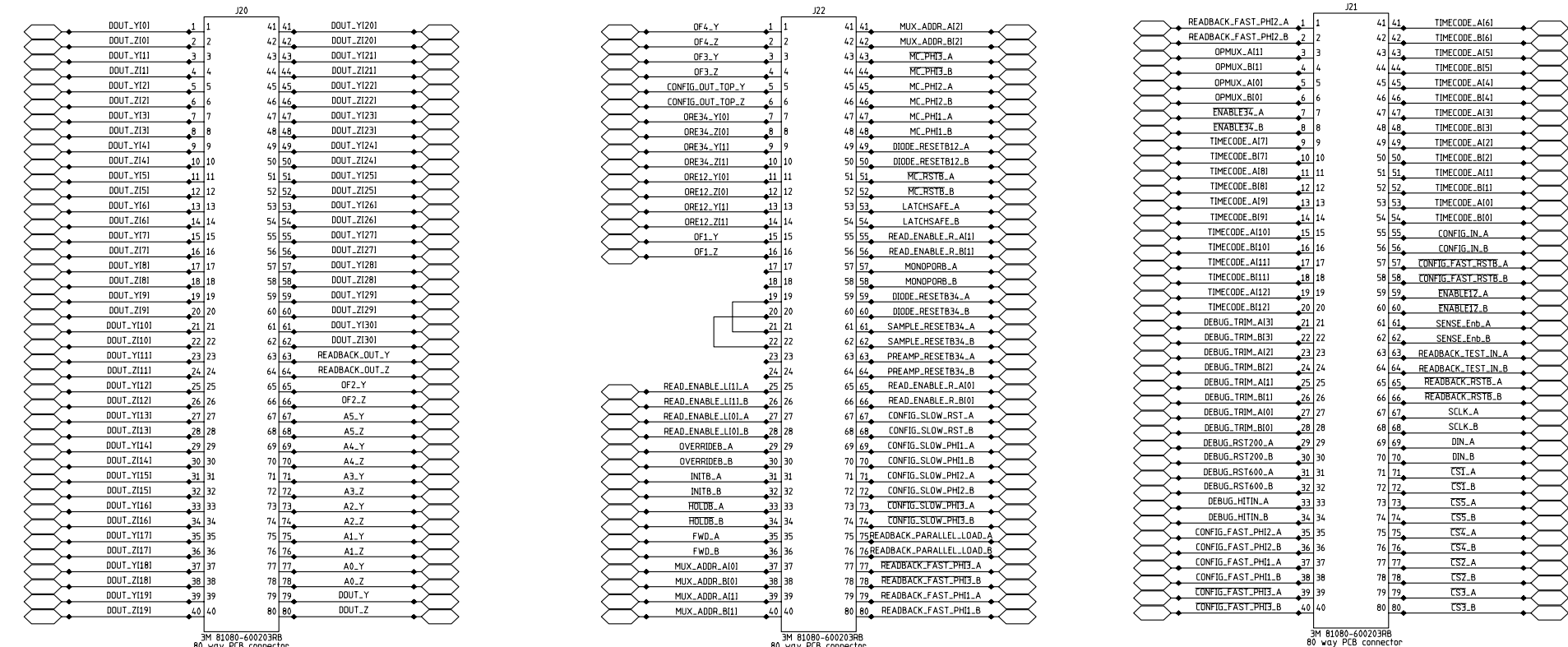

CONTRACT NO.			
APPROVALS	DATE	Connectors	
DRAWN			
CHECKED			
ISSUED			
		SIZE / FSCM NO. D	DWG. NO.
		SCALE	SHEET

REVISIONS			
REV	DESCRIPTION	DATE	APPROVED

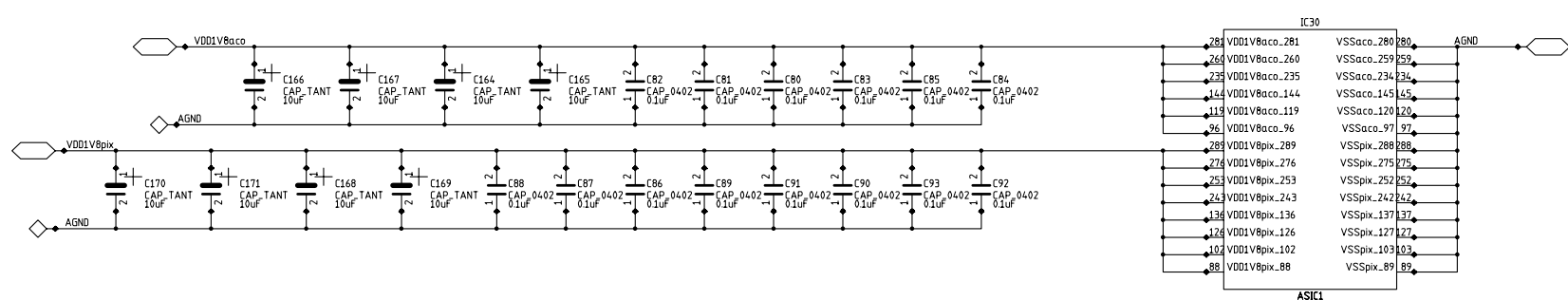
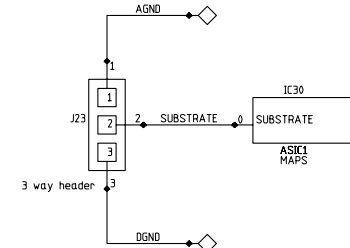
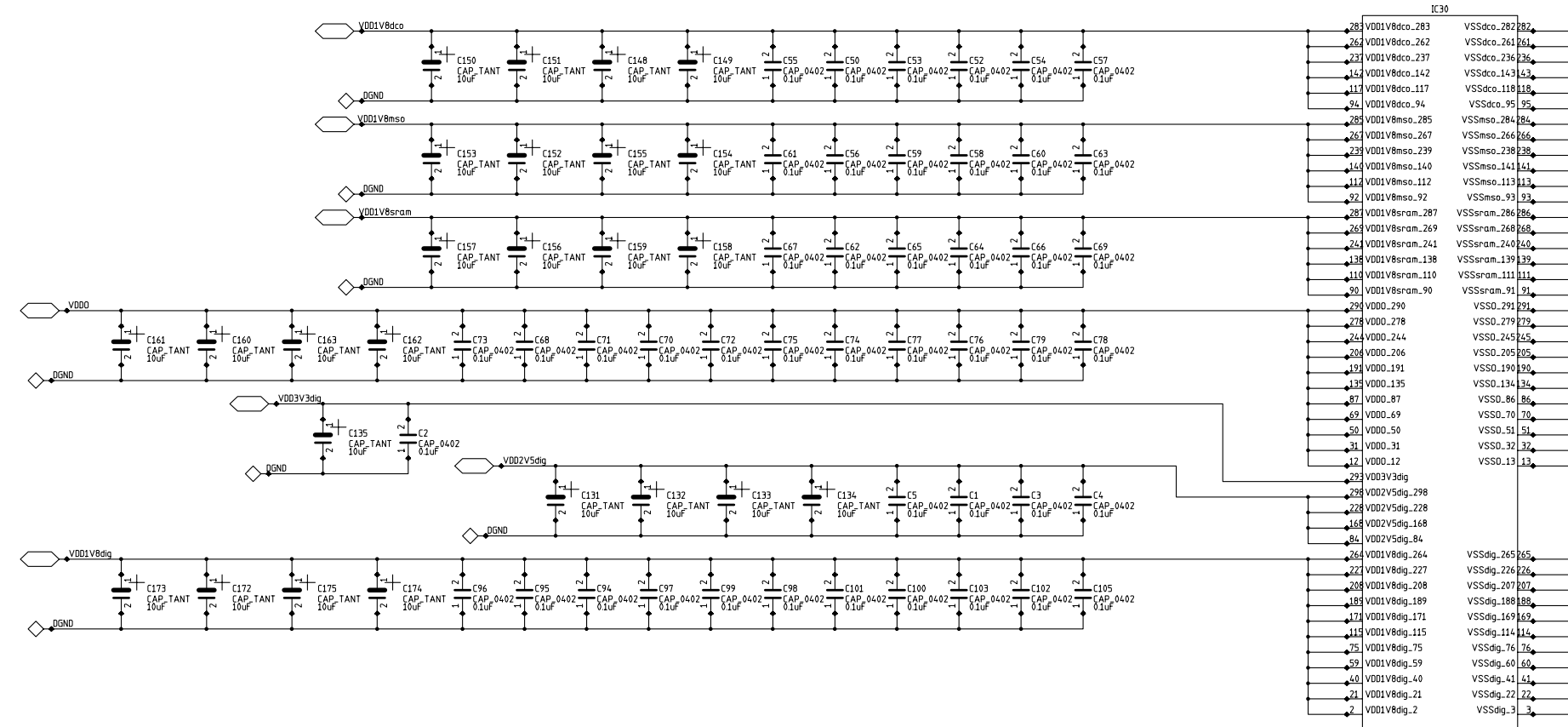

CONTRACT NO.			
APPROVALS	DATE		
DRAWN			
CHECKED			
ISSUED		SIZE / FSCM NO.	DWG. NO.
		D	
		SCALE	SHEET

REVISIONS			
REV	DESCRIPTION	DATE	APPROVED

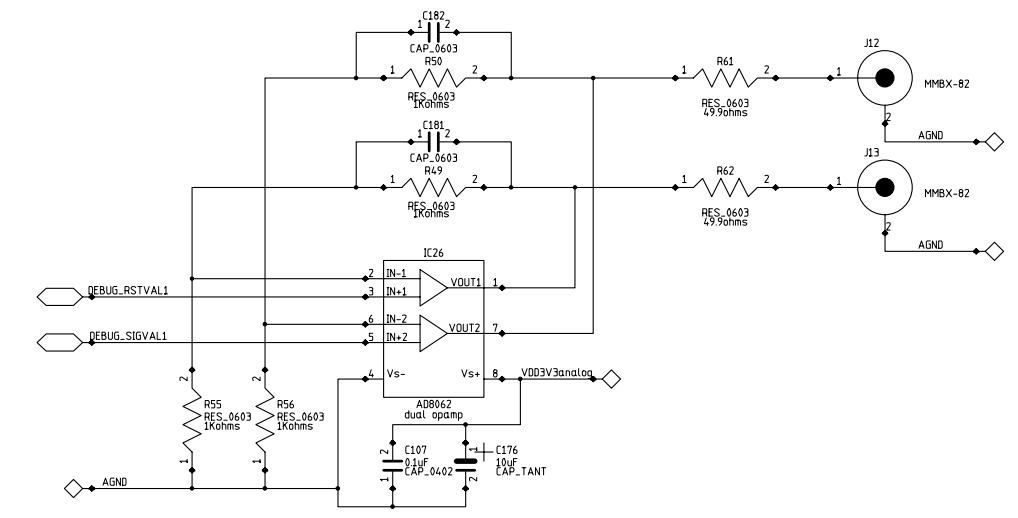
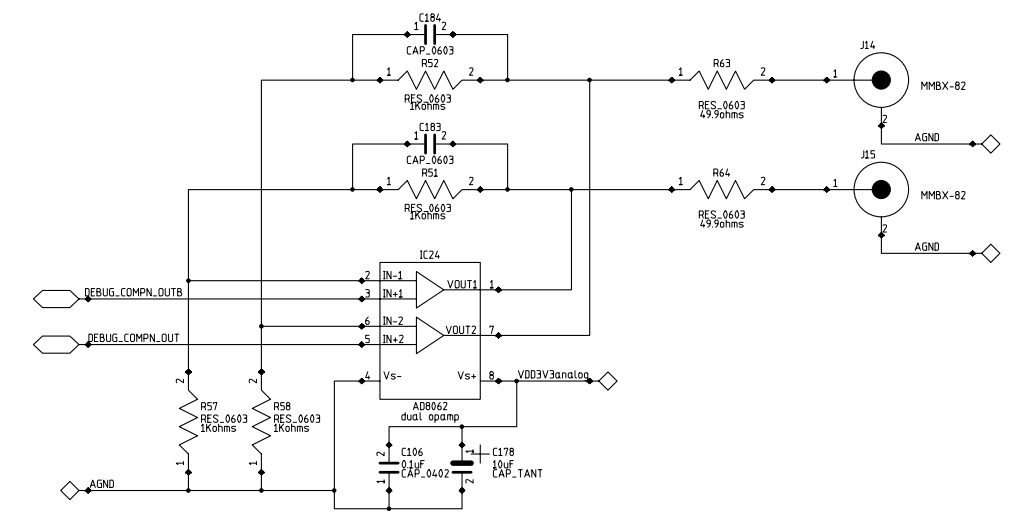
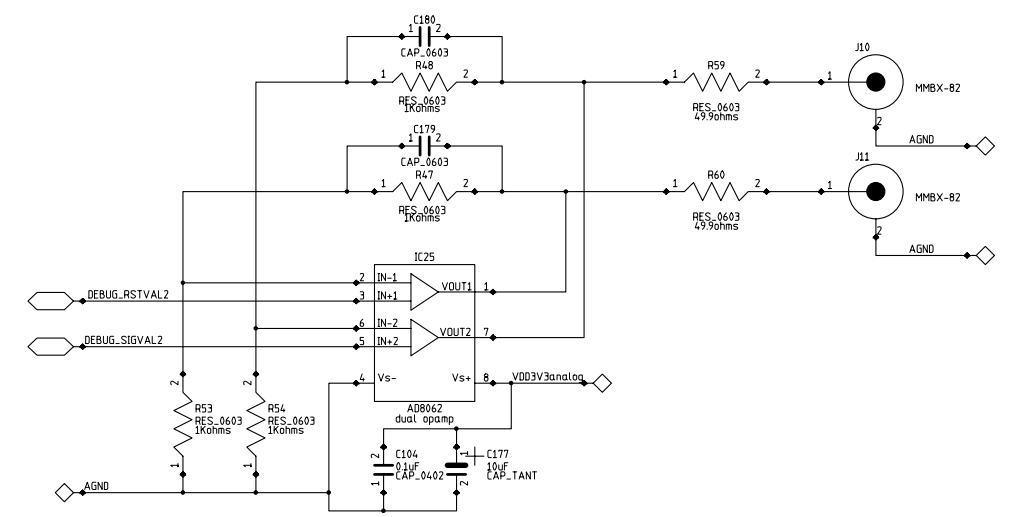

APPROVALS		DATE	Analog outputs		
DRAWN					
CHECKED					
ISSUED					
			SIZE / FSCM NO.	DWG. NO.	REV
			D		
			SCALE	SHEET	



REVISIONS			
REV	DESCRIPTION	DATE	APPROVED

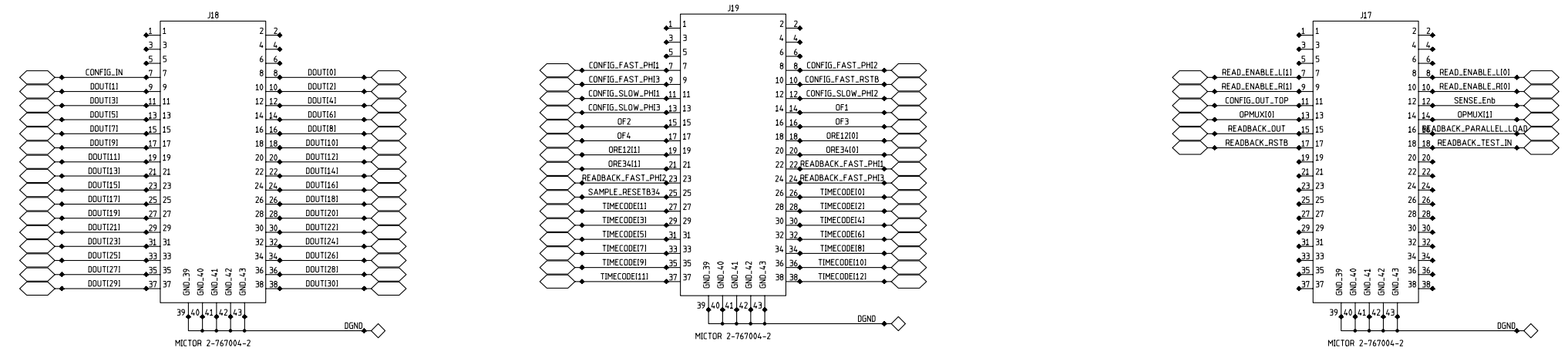

CONTRACT NO.				
APPROVALS	DATE	LA connectors		
DRAWN				
CHECKED				
ISSUED				
		SIZE / FSCM NO.	DWG. NO.	REV
		D		
		SCALE	SHEET	

DWG. NO.	SH	REV	1
REVISIONS			
REV	DESCRIPTION	DATE	APPROVED

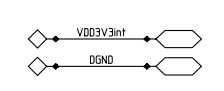
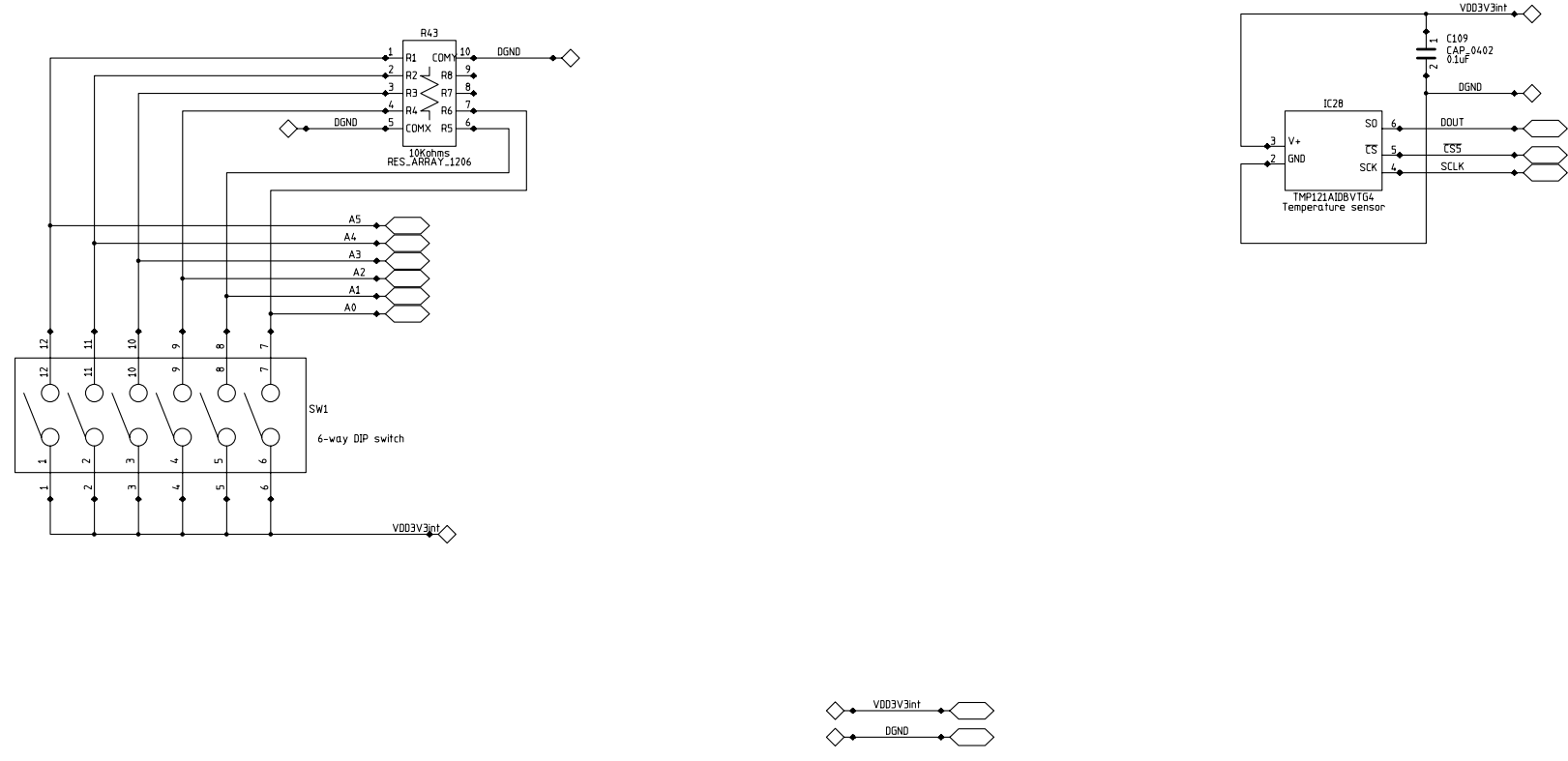

CONTRACT NO.				
APPROVALS	DATE	ID & Temp. sensor		
DRAWN				
CHECKED				
ISSUED				
		SIZE / FSCM NO.	DWG. NO.	REV
		D		
		SCALE	SHEET	